

Digital Cabinets

1-door Thawing Cabinet, 670lt, 0+10°C, standard configuration, 10 grids, R290

ITEM # _____

MODEL # _____

NAME # _____

SIS # _____

AIA # _____

725149 (TC671HDC)

1-door Thawing Cabinet, 10 stainless steel grids, 670lt, standard configuration, AISI 304, R290

Short Form Specification

Item No.

Full door thawing cabinet mainly constructed in A304 stainless steel for everlasting operation in all working environments. Fully pressed bottom plate and rounded corners; it is supplied with 10 AISI 304 grids 2/1 and the rack support can be removed without tools.

Control panel indicating the real temperature and count down evolution of the cabinet during the preservation process. The electronic control switches automatically from thawing into preservation to avoid bacteria proliferation. It is fully customizable in time, temperatures and thaw/preservation split of phases. The 3 factory-preset and 1 free program to cope with loads from approximately 20kg to 80kg.

Built-in refrigeration unit with R290 gas in refrigeration circuit.

Meets HACCP requirements. Delivered on wheels.

Main Features

- Cabinet fitted with up to 75 mm thickness of cyclopentane insulation for best insulating performance with 100% environmental protection (thermal conductivity: 0,020 W/m* K).
- Powerful fan to ensure a quick and uniform thawing process.
- Fully HACCP compliant thanks to the temperature control, visualisation and alarm management.
- Factory-preset and free program to cope with loads from approx 20kg to 80kg. All programs are customisable in time, temperatures and thaw/ preservation split of phases.
- Temperature display shows real temperature evolution allowing for frequent and brief checks during the thawing-preservation process.
- The electronic control switches automatically from thawing into preservation to avoid bacteria proliferation.
- 10 AISI 304 grids GN 2/1 supplied as standard to maximise internal space.
- The rack support can be removed without tools to speed up cleaning operations and they are dishwasher safe.

Construction

- Mainly construction in A304 stainless steel for everlasting operation in all working environment.
- Fully pressed bottom plate and rounded corners for easier cleaning.
- 4 wheels (front ones with brakes) are supplied as standard to ease cleaning operations.
- Developed and produced in ISO 9001 and ISO 14001 certified factory.

Sustainability



- CFC, HCFC, HFC-free insulation.
- CFC and HCFC free, highly ecological refrigerant type: R290 (ecological gas in foam: cyclopentane). Hydrocarbon refrigerant gas R290 for the lowest environmental impact (GWP=3), to reduce green house and ozone depletion effects.

APPROVAL: _____

Included Accessories

- 1 of 4 swivelling wheels (2 with brake), diam 125 mm, for refrigerators, NOT for remote models PNC 881002
- 10 of 2/1GN aisi 304 stainless steel grid PNC 881016
- 1 of Collecting tray in AISI 304 stainless steel for Thawing Cabinet PNC 881203
- 4 of Shelf support with 10 positions for Thawing Cabinet PNC 881291

Optional Accessories

- Spacer for 670 lt and 1430 lt refrigerated cabinets PNC 880248
- 2/1GN aisi 304 stainless steel grid PNC 881016
- Internal back air baffle/conveyor for 15 grids Thawing Cabinet PNC 881201
- Internal back air baffle/conveyor for 10 grids Thawing Cabinet PNC 881202
- Collecting tray in AISI 304 stainless steel for Thawing Cabinet with internal back air baffle/conveyor PNC 881206
- Kit 4 feet h. 100 mm for Thawing Cabinet PNC 881240
- Shelf support with 15 positions for Thawing Cabinet PNC 881290

Front

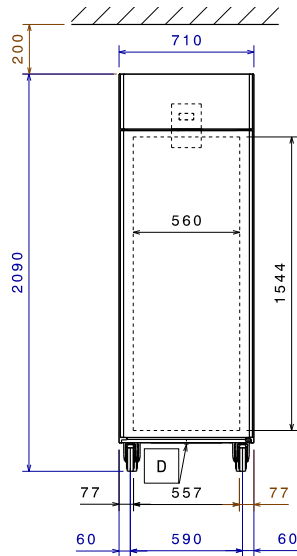

Side

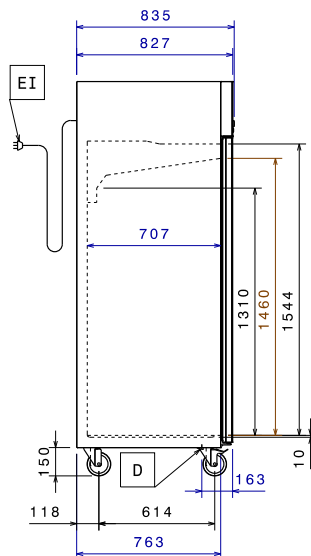

D = Drain
 EI = Electrical inlet (power)

Top

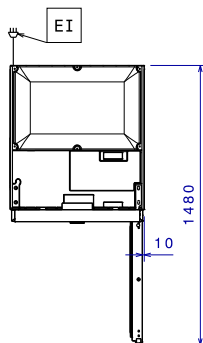

Electric

Supply voltage:	725149 (TC671HDC)	220-240 V/1 ph/50 Hz
Electrical power max.:		1.73 kW
Plug type:		CE-SCHUKO

Key Information:

External dimensions, Width:	710 mm
External dimensions, Depth:	835 mm
External dimensions, Height:	2090 mm
Internal Dimensions, Width:	560 mm
Internal Dimensions, Depth:	707 mm
Internal Dimensions, Height:	1460 mm
Net weight:	149 kg
Shipping volume:	1.58 m ³
Type of internal material:	304 AISI
Approvals	CB;CE;UKCA
Number of positions & pitch:	10; 120 mm

Refrigeration Data

Compressor power:	1/4 hp
Cooling unit:	Built-In

ISO Certificates

ISO Standards:	ISO 9001; ISO 14001; ISO 45001; ISO 50001
----------------	---

Sustainability

Refrigerant type:	R290
Refrigerant weight:	100 g
Climatic class:	5